

Custom Passive Radiator Box Design

By CJJ, TB

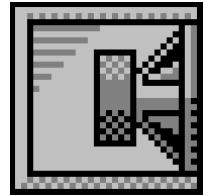

Box Properties

--Description--

Name: W5-2053

Type: Passive Radiator Box

Shape: Prism, square

--Box Parameters--

Vb = 3.2 liters

V(total) = 3.561 liters

QL = 7

F3 = 43.45 Hz

Fill = minimal

--Passive Radiators--

No. of Passive Radiators = 2

Fs = 9.085 Hz

Qms = 1.911

Vas = 40.86 liters

Cms = 5.115 mm/N

Mms = 60 g

Rms = 1.792 kg/s

Sd = 75 sq.cm

Driver Properties

--Description--

Name: W5-2053

Type: Standard one-way driver

--Configuration--

No. of Drivers = 1

--Mechanical Parameters--

Fs = 38.7 Hz

Qms = 4.7

Vas = 3.9 liters

Cms = 0.488 mm/N

Mms = 34.64 g

Rms = 1.792 kg/s

Xmax = 7.9 mm

Xmech = 11.85 mm

P-Dia = 97.72 mm

Sd = 75 sq.cm

P-Vd = 0.0593 liters

--Electrical Parameters--

Qes = 0.35

Re = 3.6 ohms

Le = 0.2 mH

Z = 4 ohms

BL = 9.308 Tm

Pe = 40 watts

--Electromech. Parameters--

Qts = 0.326

no = 0.0623 %

1-W SPL = 80.14 dB

2.83-V SPL = 83.61 dB



Wiring Diagram

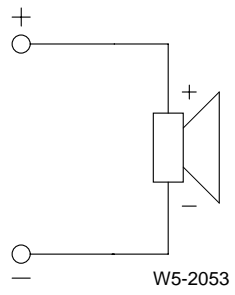

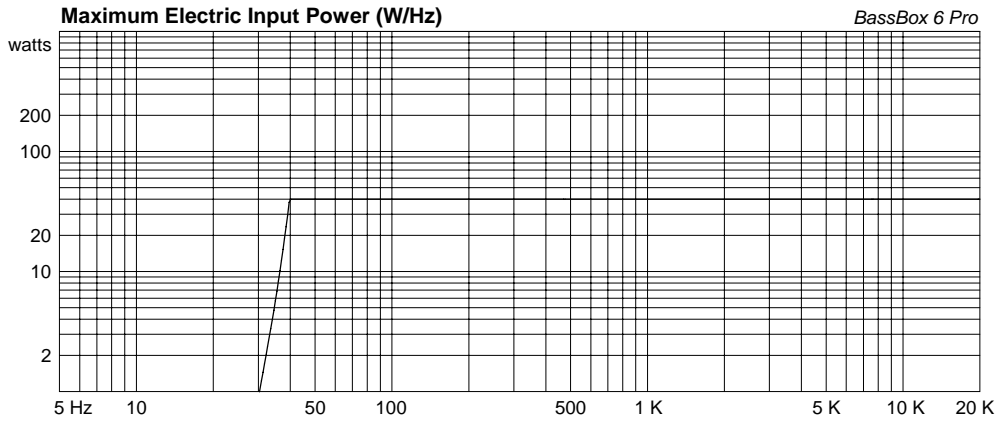
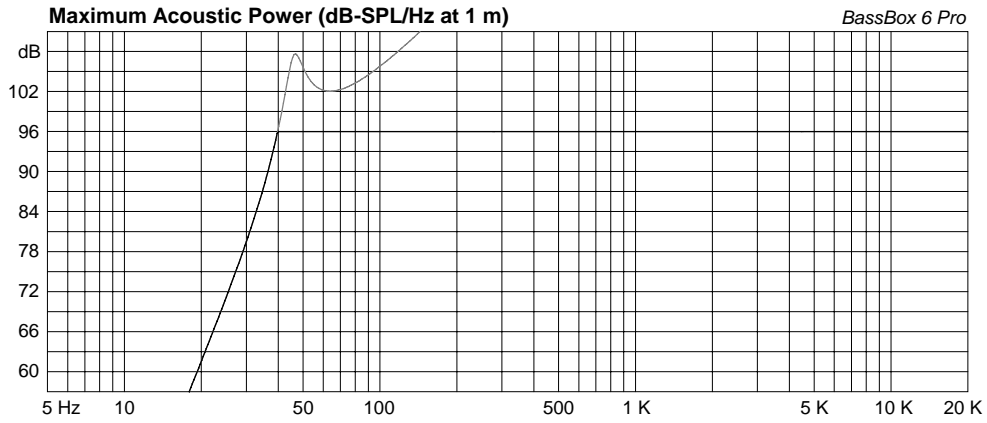
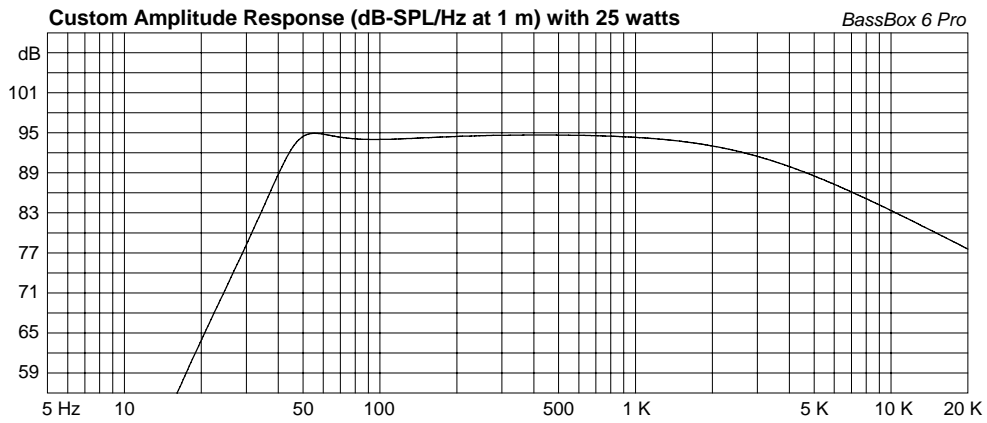
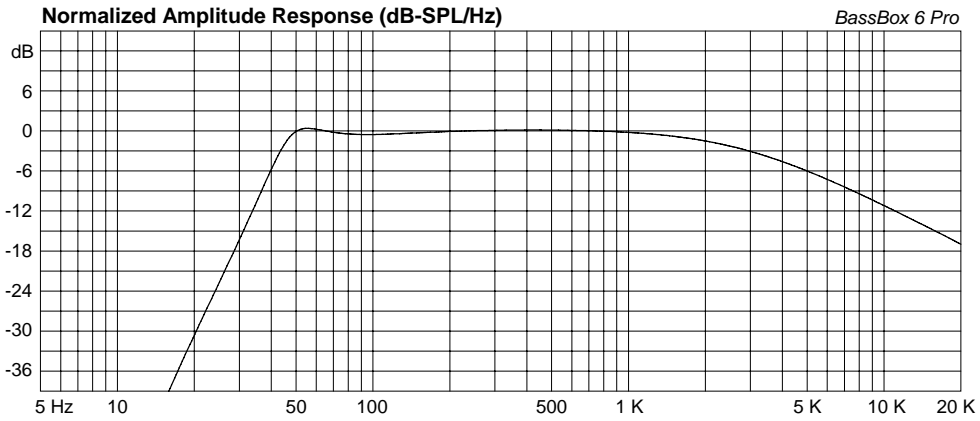

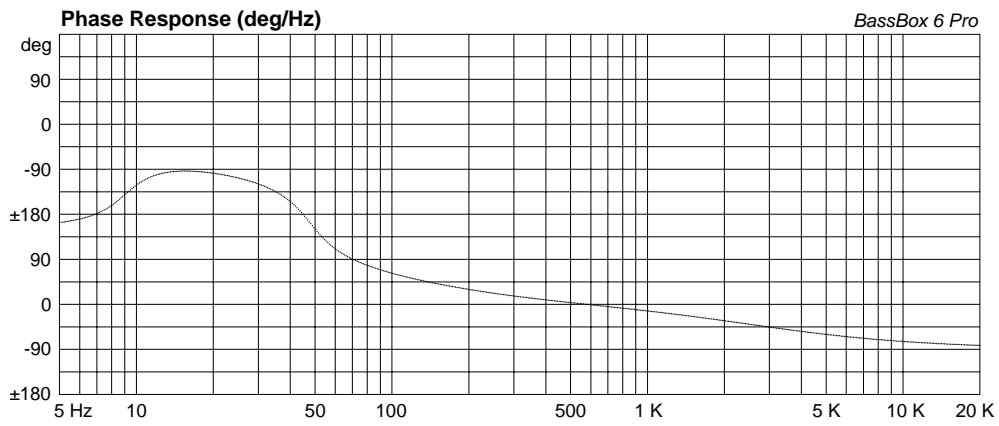
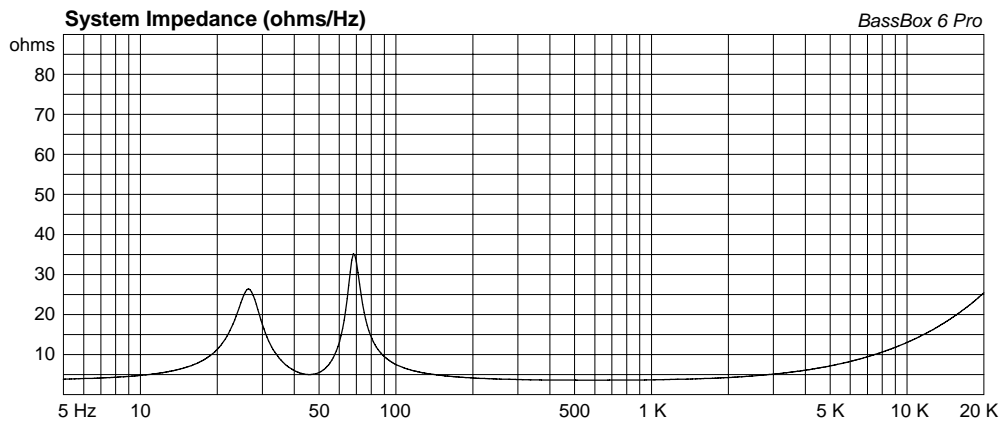
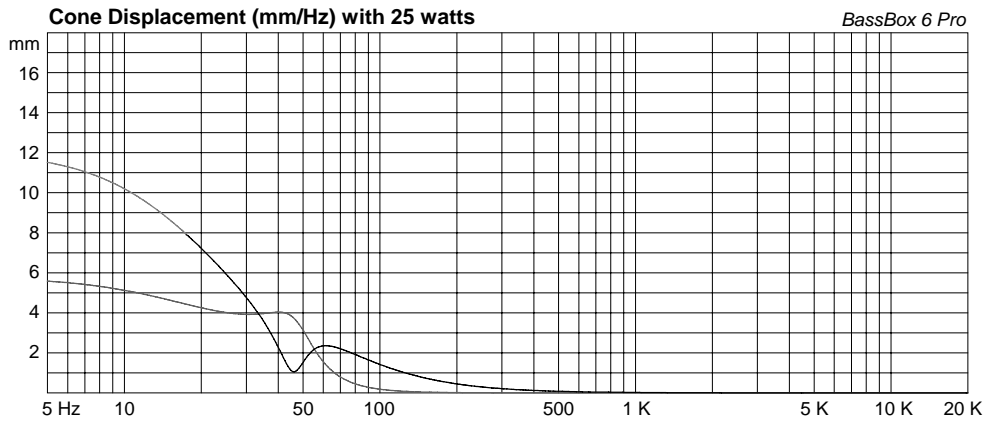

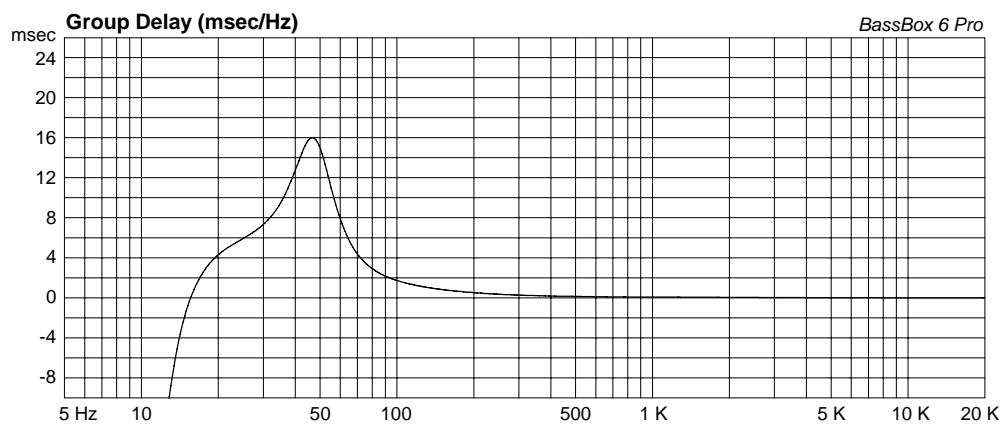

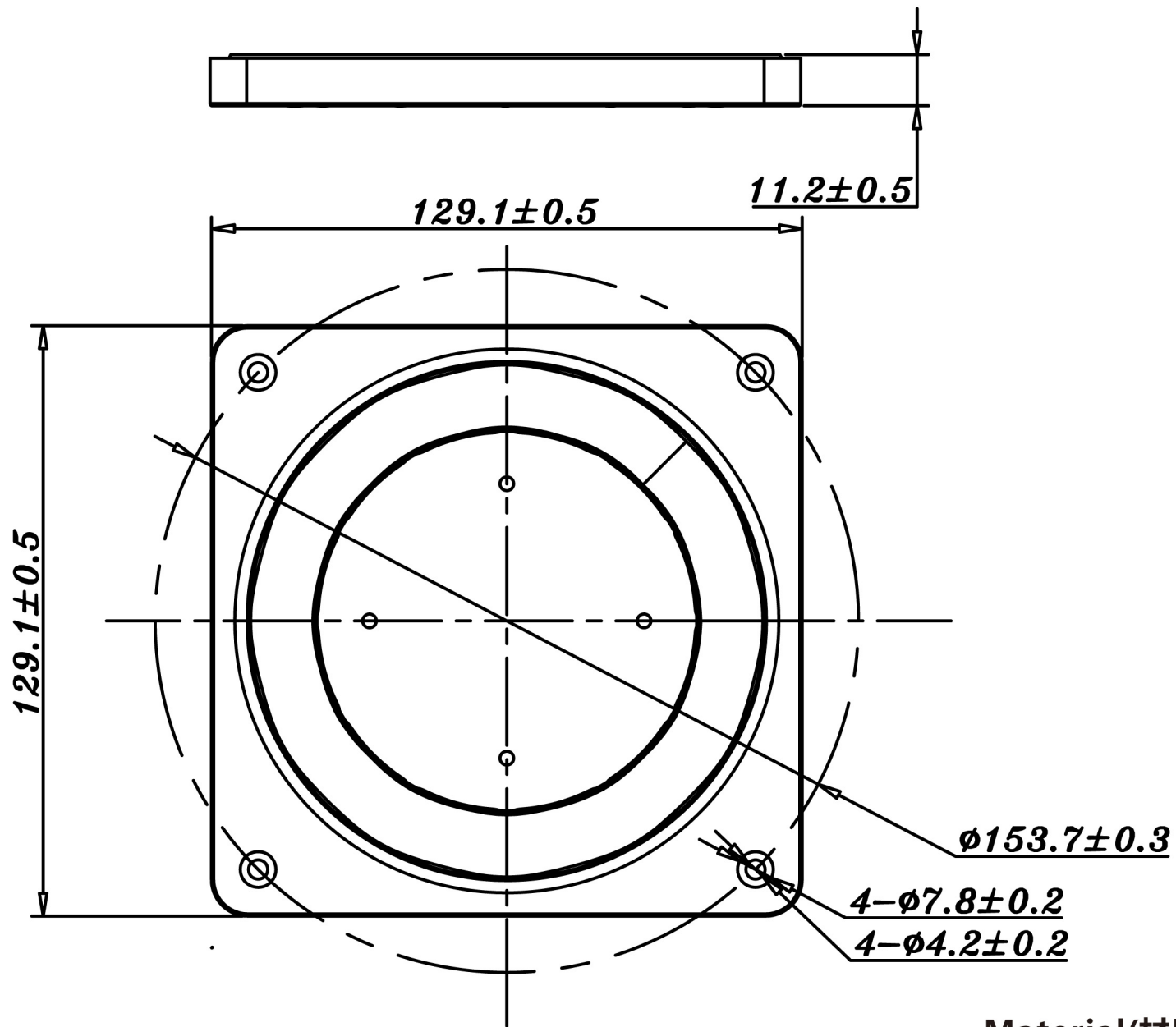

Material(材质):Rubber



PR13

Rev:R01

Date : 2015-09-07